

**LPG Association of New Zealand Inc
PO Box 1776
Wellington
New Zealand**

LPG Association of New Zealand Inc Code of Practice

In-situ Filling of LPG Cylinders

**Approved Code of Practice
Under the Hazardous Substances and New Organisms
(HSNO) Act 1996**

| | |
|------------------------------------|-------------------|
| Code of Practice Reference: | HSNOCOP 38 |
| Version: | 1.0 |
| Date of Approval: | May 2011 |

Preface

This code of practice HSNO COP 38 Version 1.0 is approved pursuant to sections 78 and 79 of the Hazardous Substance and New Organisms Act 1996 (“HSNO Act”). The Environmental Risk Management Authority (the Authority) has delegated the power to approve codes of practice to the Chief Executive of the Authority, and this Code is approved in accordance with that delegation. It is confirmed that the requirements of sections 78 and 79 have been met.

Approval of this Code is limited to matters that relate to the HSNO Act and the regulations made under that Act.

Under Regulation 62(4)(c) of the Hazardous Substances (Compressed Gases) Regulations 2004, the Authority may approve a code of practice that specifies requirements equivalent to the requirements of Regulation 62(2) for filling of gas cylinders with LPG.

Under Regulation 61(4)(b) of the Hazardous Substances (Classes 1 to 5 Controls) Regulations 2001, the Authority may approve a code of practice that specifies requirements equivalent to the requirements of Regulation 61(4)(a) for controlling ignition sources in a hazardous atmosphere zone, including dissipating static electricity.

This Code has been developed by the LPG Association of New Zealand Inc and is to provide a means of compliance for in situ filling of compressed gas cylinders with LPG, including means for dissipating static electricity during in-situ fill operations.

Notice of approval of this Code is intended to be published in the New Zealand Gazette dated 12th May 2011.

Pursuant to section 80(1) (a) of the HSNO Act, this Code may be inspected on request at the Wellington office of ERMA New Zealand. Pursuant to section 80(1) (b) of the Act, the Code can be purchased from the LPG Association, PO Box 1776, Wellington, 6140, New Zealand; website: www.lpga.co.nz ; email info@lpga.co.nz

Approved this 4th day of May 2011.

Rob Forlong
Chief Executive
ERMA New Zealand

Contents

| | |
|---|----|
| 1. INTRODUCTION | 4 |
| 2. SCOPE..... | 4 |
| 3. THE HSNO ACT AND THE PLACE OF CODES OF PRACTICE..... | 4 |
| 4. REFERENCES | 5 |
| 5. CYLINDERS | 5 |
| 6. LOCATION OF CYLINDERS | 6 |
| 7. LOCATION TEST CERTIFICATES..... | 6 |
| 8. CYLINDER FILLING..... | 6 |
| 9. HAZARDOUS ATMOSPHERE ZONES | 6 |
| 10. SUPERVISION OF FILLING ACTIVITY | 8 |
| 11. PRECAUTIONS DURING FILLING ACTIVITY | 8 |
| 12. TANK WAGON | 9 |
| 13. SUPERVISION OF TANK WAGON..... | 10 |
| 14. EMERGENCY RESPONSE PLAN | 10 |

1. INTRODUCTION

Regulation 62(2) of the Hazardous Substances (Compressed Gases) Regulations 2004 requires the weight of a charged cylinder to be checked after disconnecting the cylinder from the charging line. Regulation 62(4)(c) enables the Authority to approve a code of practice under section 79 of the Act whereby cylinders can be filled without requiring the cylinder to be weighed.

The purpose of this Code is to provide a means by which filling of cylinders by volume can be undertaken in-situ from a road tank wagon utilising an ullage or contents gauge.

This Code also provides a means for dissipating static electricity during in-situ fill operations under regulation 61(4)(a) of the Hazardous Substances (Classes 1 to 5 Controls) Regulations 2001. Information on regulation 58 for establishing and managing the hazardous atmosphere zones for in-situ filling is also included.

Compliance with this Code does not obviate the requirement to comply with other sections of the HSNO legislation (or related regulations) or other legislation such as the Health and Safety in Employment Act 1992.

2. SCOPE

This Code of Practice applies to LPG (Liquefied petroleum gas) only and to situations where the cylinders are installed on a customer's premises in their normal fixed location, have a capacity of greater than 100 litres water capacity of LPG, and are filled on site directly from a road tank wagon.

3. THE HSNO ACT AND THE PLACE OF CODES OF PRACTICE

The HSNO regulations are largely performance based, that is, they specify a desired outcome without necessarily prescribing how to achieve it. They do not require that a single specific means be used to comply with any regulation and this allows for variations in methods used for compliance.

The HSNO Act provides for codes of practice approved by the Authority to identify acceptable solutions to comply with the specified regulatory requirements. An approved code of practice provides users with a method of meeting the control requirements with a degree of prescription and assistance.

In addition, specific provisions of the HSNO regulations and Gazetted transfer notices permit codes of practice to be approved by the Authority as alternatives to other specified requirements provided they can be shown to provide an equivalent level of self management.

4. REFERENCES

Hazardous Substances (Compressed Gases) Regulations 2004

Hazardous Substances (Tank Wagons and Transportable Containers) Regulations 2004.

Hazardous Substances (Dangerous Goods and Scheduled Toxic Substances) Transfer Notice 2004 (as amended):

AS/NZS 60079.10.1: 2009 Explosive atmospheres - Classification of areas - Explosive gas atmospheres (IEC 60079-10-1, Ed.1.0 (2008) MOD)

AS/NZS 1596: 2008 The storage and handling of LP Gas

5. CYLINDERS

Cylinders used for in-situ filling shall:

1. Incorporate a filling connection with a 1³/₄ inch – 4 TPI male right hand external ACME thread and non return valve, and
2. Be fitted with either:
 - a. An automatic fill limiter (AFL) that stops the filling at 80% of the cylinder water capacity when being filled, or
 - b. An automatic fill limiter (AFL) as above, that also incorporates a fixed level ullage valve to allow checking, or
 - c. A fixed liquid level gauge, which shall indicate a maximum liquid level 4 litres less than the standard filling level for the cylinder, and
3. Cylinders that are compliant with this Code and are filled with an AFL without an ullage valve shall be marked with a beige stripe extending diagonally across the shoulder.

Note that under option 2a above, cylinders trigger a lesser hazardous atmosphere zone (see section 9), provided they are marked with a beige stripe.

When the filling connection of the in-situ fill cylinder does not have a manual valve, a removable adaptor shall be attached to the cylinder filling connection. The removable adaptor shall incorporate a non-return valve arranged to prevent outward flow of product from the cylinder when the filling hose is removed. The adaptor shall not be removed until it has been ascertained that the non-return valve of the cylinder has closed correctly after filling, i.e. the adaptor has been depressurised through a bleed valve. If the non-return valve of the cylinder has not closed correctly, the adaptor shall be left in place until the fault is rectified.

6. LOCATION OF CYLINDERS

The cylinders to be filled in-situ by pumping from a road tank wagon shall comply with the following location requirements **in addition to the requirements of Schedule 10 of the Hazardous Substances (Dangerous Goods and Scheduled Toxic Substances) Transfer Notice 2004 (as amended):**

1. The cylinders shall be located outdoors, and
2. Any opening into a building shall not lie within 500 mm above the cylinders, and any opening into a building or pit or drain shall not lie within 1000 mm from the side of any cylinder holding up to 100kg of LPG, and shall not lie within 2000 mm from the side of any cylinder holding more than 100kg of LPG, and
3. The cylinders shall be incapable of falling e.g. shall be restrained, and
4. The cylinders shall be on a stable base that is not prone to indentation over time. This base shall be raised at least 50 mm above the surrounding level and shall shed water.

7. LOCATION TEST CERTIFICATES

Prior to the first in-situ fill, there must be a location test certificate issued by a test certifier that certifies the location is compliant for in-situ filling of the cylinders. This certificate must be renewed at intervals not more than twelve months or the location must pass a compliance check in accordance with a code of practice approved by the Authority.

8. CYLINDER FILLING

In-situ filling shall be undertaken only by connecting the fill hose directly onto the fill connection of the cylinder.

The pumping rate shall be appropriate to the size of the cylinder. To minimise the risk of overfilling, and taking into account operator reaction time, a cylinder shall not be filled in less than 60 seconds.

Cylinder filling shall not be undertaken at night time or in poor light, unless all essential gauges, connections and valves have been illuminated by fixed or temporary lighting. The lighting must comply with electrical standards for the delineated hazardous atmosphere zones.

Before an LPG delivery hose is connected, it is important to ensure that the operator and the storage cylinder are at the same electrical potential. The operator will achieve this by touching the cylinder with a bare hand while holding the nozzle of the hose delivering the LPG. This is to prevent the possibility of an ignition spark by the discharge of static electricity which may have built up in the operator's body.

9. HAZARDOUS ATMOSPHERE ZONES

Hazardous atmosphere zones must be delineated and identified in accordance with AS/NZS 60079.10.1:2009. Examples of setting hazardous atmosphere zones about cylinders taken from Annex ZA 6.5.2.16 and 17 of AS/NZS 60079.10:2009 are shown in Appendix 1.

The examples illustrate how the situation of the cylinder will change the hazardous atmosphere zone. Figure ZA 42 refers to an exchange cylinder and applies to a cylinder which is fitted with an automatic fill limiting device when being filled in situ, as no gas is bled during filling. The hazardous atmosphere zone typically extends out to 1.5 m from the base of the cylinder.

Figure ZA 43 refers to an in situ fill cylinder and covers the case where the cylinder is **not** fitted with an automatic fill limiting device. The cylinder will typically have a fixed level ullage gauge and gas is bled during filling. Accordingly, the hazardous atmosphere zone extends out to 3.5 m from the base of the cylinder.

Further reference should be made to AS/NZS 60079.10.1:2009 to identify how site specific issues must be taken into account. The site specific issues include ventilation, climate, topography and presence of structures in the vicinity. For example, in inadequately ventilated locations, and if the ullage valve is open longer than limited periods for contents checking, the hazardous atmosphere zone will extend further.

The area within the identified hazardous atmosphere zone shall be checked for compliance with that zone prior to filling the cylinder.

During the filling operation any openings into the building which fall within the hazardous atmosphere zone must be closed.

Hazardous atmosphere zones also exist at the LPG tank wagon. These are typically around connections and fittings. A diagram indicating the hazardous atmosphere zones during the discharge of LPG shall be retained in the cab of the tank wagon. The driver will check joints, flanges and pump connections for any sign of a leak at the start of each day and take remedial action where necessary. The hazardous atmosphere zone about the tank wagon shall be checked for compliance prior to filling the cylinder. Any electrical equipment that is required to be active during the transfer of LPG and that is located within a hazardous atmosphere zone shall be suitable for use in such a zone.

10.SUPERVISION OF FILLING ACTIVITY

The cylinder filling may be undertaken by one person provided:

1. The person undertaking the filling of the cylinders is an approved handler¹ and an approved filler², and
2. The person can maintain surveillance of both the in-situ fill cylinder and the tank wagon during the filling operation i.e. the cylinders and tank wagon must be in the person's direct line of sight, with no more than a deviation of 1.5 m from the direct line of sight, and
3. There is direct unobstructed access between the tank wagon and the cylinder fill point, and
4. There is no more than 50 m of hose length between the tank wagon and the cylinder fill point, and
5. The filler has a remote shut down device for the tank wagon as specified in section 12.1.

Where these requirements are not met, there shall be at least two persons in attendance - one at the tank wagon and one at the cylinder fill point, and there shall be at least one approved handler and one approved filler.

11.PRECAUTIONS DURING FILLING ACTIVITY

11.1. LPG Cylinder

Prior to commencing filling operations, the cylinders intended to be filled shall be checked to ensure they are approved LPG cylinders. The cylinders shall not be filled unless they are in serviceable condition and within the test period for the cylinder.

11.2. Preparation of cylinders

A check shall be undertaken to determine whether there is any LPG in the cylinders that are to be filled. In the case of a gas out situation (no LPG) with any cylinder, the cylinder outlet valve shall be closed before filling is commenced, and site staff advised. If the site is not staffed at the time of delivery, a written note shall be left that outlet valve(s) are closed.

11.3. Delivery hose

The delivery hose shall not pass through any buildings or cross any carriageways, with the exception that the building is an open carport or veranda.

¹ A person who holds an approved handler test certificate issued by a test certifier who is approved to certify the competence of approved handlers.

² A person who holds an approved filler test certificate issued by a test certifier who is approved to certify the competence of approved fillers

11.4. Personal Protective Equipment

The person undertaking the filling shall wear personal protective gloves.

11.5. Leakage Check

The cylinder shall be checked for leakage after filling using a standard soapy water test.

11.6 Filling to cease

Where the conditions of this Code cannot be met, the filling shall cease.

12.TANK WAGON

The tank wagon used to fill in-situ cylinders shall comply with the requirements of the Hazardous Substances (Tank Wagons and Transportable Containers) Regulations 2004.

12.1. Control of LPG delivery

For single operator deliveries there shall be a remote shut down device that:

1. Can close all tank valves, shut down the pump supplying liquid and pump bypass connections, and shut down the tank wagon engine, and
2. Is of a fail safe design, and
3. Provides shut down as quickly as possible, but no more than 12 seconds, and
4. It shall operate at a distance no less than 50 m.

The operator shall keep the remote control device on their person at all times when filling the cylinder.

The remote shut down device shall be maintained in a safe working condition at all times. The functionality shall be tested daily, and the device shall be inspected every two years.

12.2. Tank wagon position for in-situ filling

The tank wagon shall be positioned for in-situ filling of cylinders as follows:

1. All practical steps shall be taken to park the tank wagon off public roads, and
2. Warning signs shall be provided to exclude sources of ignition and to comply with the requirements of the HSE Act, and
3. The tank wagon shall be parked so that it can be readily driven or towed away in an emergency without recourse to reversing, and
4. The tank wagon shall not obstruct entrances to buildings or obstruct fire escapes and shall be located as far as practical from open doorways.

The tank wagon shall be no larger than 10,000 litres water capacity.

13.SUPERVISION OF TANK WAGON

The Hazardous Substances (Tank Wagons and Transportable Containers) Regulations 2004 shall be complied with. This includes Regulation 41:

41 Supervision of tank wagons

(1) Despite regulation 56 of the Hazardous Substances (Classes 1 to 5 Controls) Regulations 2001 and regulation 9 of the Hazardous Substances (Classes 6, 8, and 9 Controls) Regulations 2001, the person in charge of a tank wagon that contains a liquid hazardous substance or gaseous hazardous substance of any hazard classification may leave that tank wagon unattended—

(a) if the tank wagon is in a transit depot; or

(b) for up to 5 minutes if the tank wagon—

(i) is not less than 30 m away from an area of high intensity land use; or

(ii) is not less than 8 m away from an area of low intensity land use.

*(2) For the purposes of subclause (1), the terms **area of high intensity land use**, **area of low intensity land use**, and **transit depot** have the same meaning as in regulation 3 of the Hazardous Substance (Classes 1 to 5 Controls) Regulations 2001.*

14.EMERGENCY RESPONSE PLAN

An emergency response plan shall be available and the person undertaking the filling shall be familiar with the plan. The emergency response plan shall:

- be kept current, and
- be retained on the vehicle, and
- be compliant with the requirements of both the HSNO Act and the Land Transport Act.

Appendix 1 Cylinder Hazardous Atmosphere Zones

ZA.6.5.2.16 Cylinders, adequately ventilated, whether in storage or installed for use, exchange type (See Figure ZA.42)

Within space 0.5 m above and 0.5 m laterally from any cylinder valve, extending to a distance of 1.5 m laterally at the base of the cylinder **Zone 2**

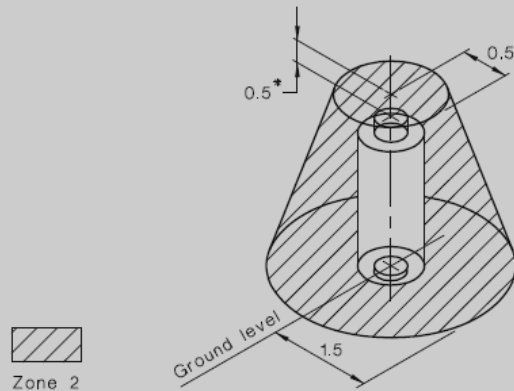

* This dimension is measured from the top of any cylinder valve

Dimensions in metres

Figure ZA.42 – Exchange cylinder

ZA.6.5.2.17 Cylinders, whether in storage or installed for use, adequately ventilated, in situ fill type (with limited gas bleeding for contents checking) (See Figure ZA.43)

Within space 0.5 m above and 1.5 m laterally from any cylinder valve, extending to a distance of 3.5 m laterally at the base of the cylinder **Zone 2**

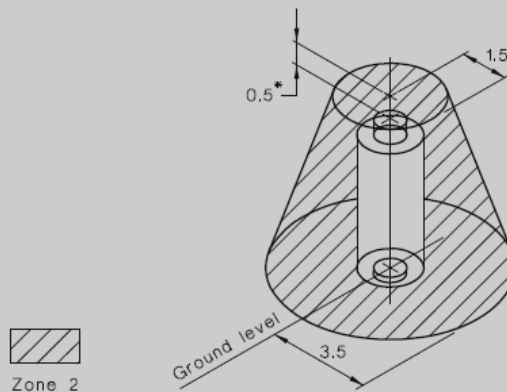

* This dimension is measured from the top of any cylinder valve

Dimensions in metres

Figure ZA.43 – In situ fill cylinder

Taken with permission from AS/NZS 60079.10.1:2009.